

ADULT DIAPER

Product Introduction

BKAMED Adult Diaper is the ultimate solution for those seeking comfort, reliability, and discreet protection. Crafted with the highest quality materials, it offers an exceptional blend of softness and durability. Designed to meet the needs of individuals who require superior absorbency and a secure fit, the BKAMED Adult Diaper ensures peace of mind and confidence throughout the day and night.

PE FILM VS CLOTH-LIKE



PE Film

Feature a smooth and protective outer surface, designed to ensure reliable containment and secure performance.



Non-Woven Fabric

Provide a soft and breathable surface, delivering consistent protection and comfortable wear.

| Category | PE Film | Cloth-Like |
|-----------------------|--|--|
| Outer Material | Polyethylene film (plastic-like, smooth, high-gloss finish) | Non-woven outer layer (fabric-like, matte, enhanced softness) |
| Breathability | Non-breathable; Fully sealed film ensures maximum leakage prevention | Breathable, engineered for airflow, reducing skin irritation and rashes |
| Comfort & Skin Health | May cause sweating and mild discomfort during extended use | Gentle, skin-friendly design for reducing risk of rashes, preferred by sensitive users |
| Cost | Economical production and pricing | Higher production cost, priced as a premium solution |

PRODUCT RECOMMENDATION

ECONOMY 700-900ml

Designed for daily comfort and light protection, the Economy range provides reliable absorbency at an affordable cost. Ideal for short-term use or light incontinence

PLUS 1000-1400ml

Enhanced absorbency for moderate protection, the Plus range offers improved leakage control and longer wear time. Perfect for active users who need extra security during the day.

OVERNIGHT 1600-1800ml

Specially engineered for extended night-time use, the Overnight range ensures maximum absorbency and dryness throughout long hours of rest, reducing changes and ensuring comfort until morning.

ULTRA THICKT 2200-2400ml

The highest level of protection and durability, Ultra Thick diapers are designed for users requiring maximum absorbency and reliable leak prevention, suitable for hospital care, long travel, or heavy incontinence needs.

Recommended absorbency levels are provided as guidance, but they can be customized according to local market preferences and client requirements.

All absorbency values are tested and verified in accordance with the European ISO 11948-1 standard.

CUSTOMIZE YOUR PRODUCT

Tape

Multiple fastening tape styles are available to meet different market preferences and user needs.

Ultra Soft

Extra-soft material with different softness levels to provide tailored comfort and skin protection

Leak Guard

Customizable frontal landing zone with the option to print customer logos or brand designs, enhancing brand visibility and product differentiation.

Wetness Indicator

Offered in multiple design options (single-line, dual-line, or pattern-based), providing clear and reliable change-time signals.

Elastic Waist

Flexible waistbands that adapt to body shape, customizable in strength and elasticity for a secure yet comfortable fit.

SAP

High-performance absorbent materials available from Japan, Taiwan, and Germany, offering different retention levels and liquid-locking efficiency.

ADL

Available in blue or white, designed to rapidly transfer liquid to the absorbent core for improved dryness.

Front Tape

Customizable frontal landing zone with the option to print customer logos or brand designs, enhancing brand visibility and product differentiation.

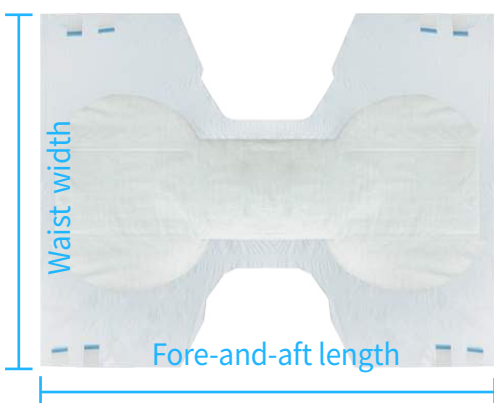
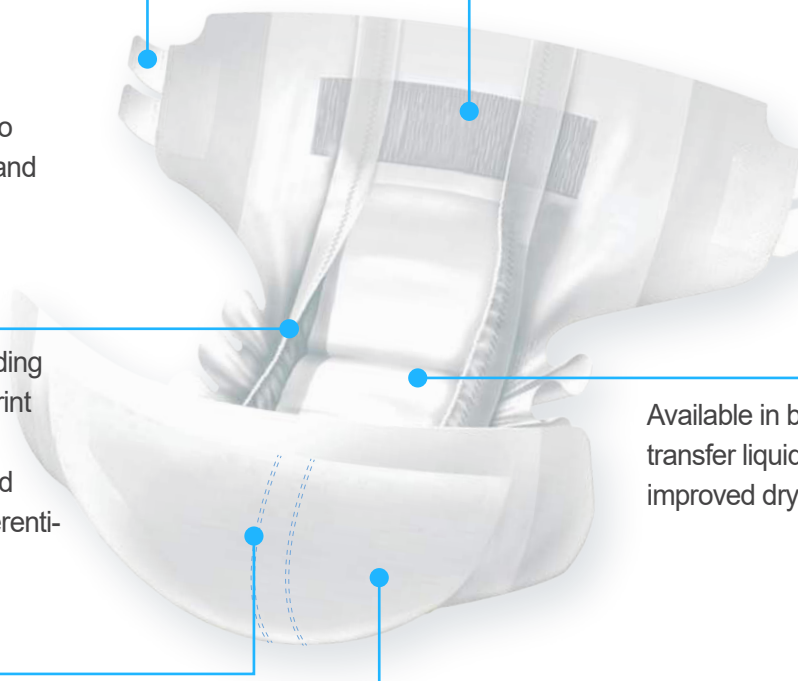

| Size | S | M | L | XL | XXL |
|--------|-------|-------|-------|-------|--------|
| Length | 720mm | 800mm | 900mm | 960mm | 1090mm |
| Width | 650mm | 650mm | 750mm | 800mm | 840mm |

*Minimum width: ≥ 650 mm Maximum width: ≤ 840 mm Minimum length: ≥ 720 mm
Maximum length: ≤ 2100 mm

Dimensions can be adjusted within the specified range to accommodate customer requirements.

PACKAGE



Cost-effective, durable, full-color gravure printing for high-quality presentation



Equipped with plastic or die-cut handle; convenient for carrying and brand display.

DISPOSABLE UNDERPAD

Product Introduction

Material structure:

BKAMED disposable underpads are available in 4–7 layer options, composed of non-woven fabric, tissue paper, SAP, wood pulp, and PE film.

Product specifications:

Width: 10–80 cm × Length: 10–180 cm.

Custom sizes can be produced upon request.

Packing specification:

10–100 pieces per bag, with flexible packing customization available.

PRODUCT CUSTOMIZATION

Size/ Weight/ Package/ Edge Folded/ Color

● Size

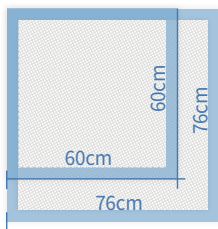

23"x24"
(60x60cm)

30"x30"
(76*76cm)

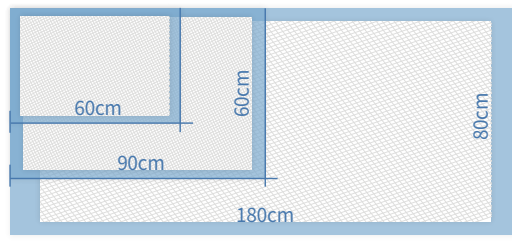

17"x24"
(40x60cm)

23"x36"
(60*90cm)

31.5"x71"
(80*180cm)

Other size

BKAMED disposable underpads are available in a wide range of dimensions to meet different market and usage requirements. Customized sizes are available upon request.

● Measurement of dimensions

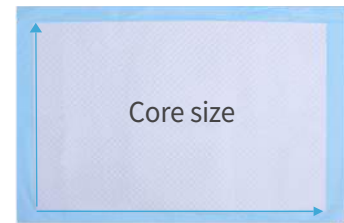
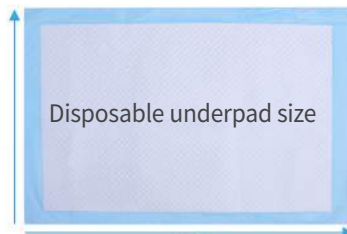

Each underpad has two measurement standards: Disposable Underpad Size – the full external dimension of the pad. Core Size – the absorbent core dimension, smaller than the full pad, ensuring effective liquid absorption and leakage protection.

● Package



Color bag



Polybag with sticker



Compression packing



*NODA can provide you free packaging design

BKAMED offers a variety of flexible packaging options to suit different market needs:

Color Bag – premium printed design for retail display. Polybag with Sticker – economical and practical choice. Compression Packing – reduces volume, saves storage and transportation costs. Customized packaging design is available free of charge.

● Color



Pink



Blue

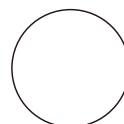

White



Green



Orange

PRODUCT RECOMMENDATION

| Size(cm) | Inch | Absorbency(ml) | Recommended Use |
|----------|-----------|----------------|---|
| 40X60 | 17"x24" | 300-600 | Compact size, suitable for pets, travel, or light daily protection. |
| 60X60 | 24"x24" | 300-800 | Standard square pad for general use at home or in clinics. |
| 76X76 | 30"x30" | 500-2500 | Larger coverage, ideal for elderly care or extended night use. |
| 60X90 | 24"x36" | 500-2000 | Popular hospital and adult care size, provides reliable protection. |
| 80X180 | 31.5"x71" | 800-3000 | Full-bed protection, recommended for ICU bedridden patients, or maximum coverage needs. |

CUSTOMIZE YOUR PRODUCT

SAP

Enhances absorption and locks in moisture; available from Japan, Germany, or Taiwan to meet different market and brand requirements.

Edge Folded Design

Provides additional leakage protection and a clean finish.

Multiple Backsheet Options

Anti-slip PE film, various colors, dotted design, or customized logo printing.

Embossing

Available in multiple patterns to ensure even liquid distribution and support brand differentiation.

Layers (4–7 options)

Different layer structures available to meet various absorbency and comfort requirements.

Fragrance / Odor Control

Optional fragrance or odor-neutralizing additives to enhance freshness and improve user comfort.

Adhesive Sticky Tape

Corner strips or full-length strip options for secure fixation.

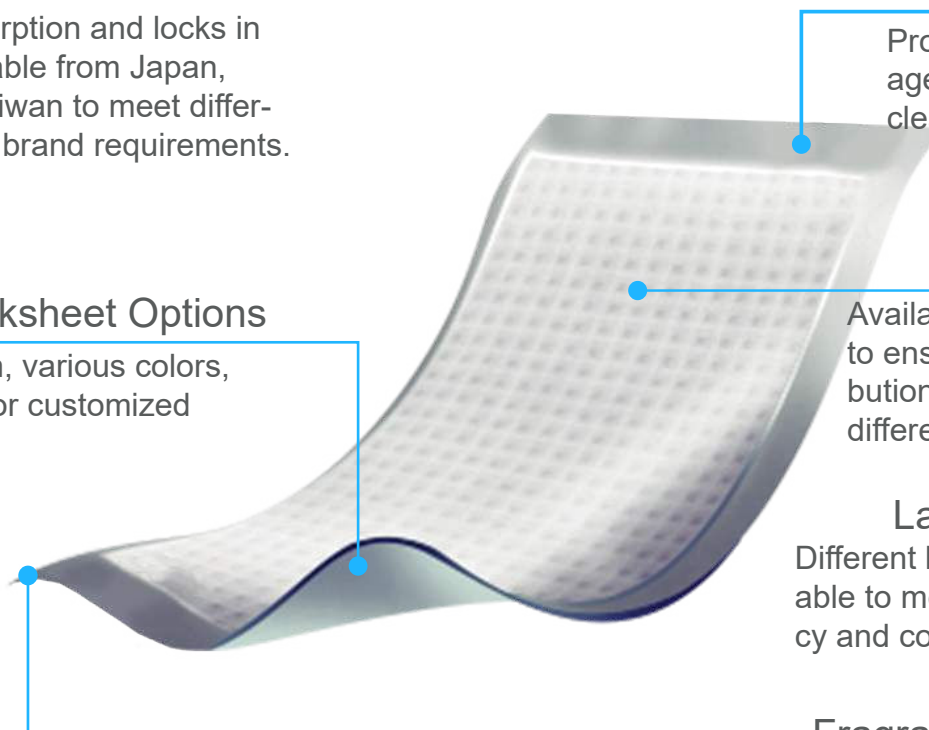



DISPOSABLE PET TRAINING PADS

OEM & ODM DISPOSABLE PET TRAINING PADS

We provide high-quality, customizable pet care solutions for clients worldwide. Whether you are a start-up brand or a large retail chain, we can tailor size, absorbency, packaging, and brand design to help your product stand out in the market.

PRODUCT CUSTOMIZATION

Sizes can be precisely customized in centimeters

| Size Category | Common Sizes (cm) | Suitable For / Usage |
|---------------|-------------------------|--|
| Small | 33×45 / 40×50 / 45×60 | Small dogs, puppies, cats, travel crate liner |
| Medium | 53×53 / 53×60 / 60×60 | Medium dogs, daily indoor training |
| Large | 60×75 / 60×80 / 60×90 | Large dogs, long-time use, travel |
| Extra Large | 80×90 / 80×100 / 90×120 | Multiple pets, whelping area, waterproof floor cover |

Adjustable Absorbency: 300ml~1500ml+, 300ml to 1500ml+, adjustable absorbent core weight.

| Absorbency Level | Absorption Capacity (approx) | Suitable Usage |
|-------------------|------------------------------|---|
| Light Absorbency | 300-500 ml | Ideal for puppies, kittens, or short-term use |
| Medium Absorbency | 500-800 ml | Daily indoor training, adult small dogs |
| High Absorbency | 800-1200 ml | Long-time use, large dogs, overnight use |
| Ultra Absorbency | 1200-1500+ ml | Multiple pets, long trips, whelping area |

● Package



Color bag



Polybag with sticker



Compression packing



*NODA can provide you free packaging design

● Color



Pink



Blue

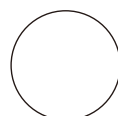

White



Green









Orange

DISPOSABLE PET TRAINING PADS



TYPES OF PET TRAINING PADS

| Category | Features | Suitable Usage | Example diagram |
|--------------------------------|--|--|---|
| Standard Pads | Economical and practical, moderate absorbency, single-use | Daily indoor training, short-term use |  |
| High-Absorbency Pads | Enhanced with more super absorbent polymer (SAP) for high capacity and leak protection | Overnight use, large dogs, extended periods without changing |  |
| Activated Carbon Pads | Contains an activated carbon layer to effectively absorb odors | Long indoor use, odor-sensitive households |  |
| Scented Pads | Infused with light scents (e.g., lemon, lavender) to attract pets | Puppy training, odor reduction |  |
| Anti-slip Pads | Anti-slip backing prevents movement | Active dogs, smooth or slippery floors |  |
| Printed Pads | Decorative printed topsheet for visual appeal | Pet shows, premium pet stores |  |
| Reinforced Tear-resistant Pads | Strengthened surface to resist scratching and tearing | Pets that scratch, multi-pet households |  |

PULL-UP PANTS

Product Introduction

Designed for users who prioritize convenience and dignity, BKAMED Pull-Up Pants feature a 360° elastic waistband for one-pull wear and one-tear removal, ensuring unrestricted movement. Its invisible ultra-thin design resembles regular underwear when worn, eliminating privacy concerns. Equipped with a high-molecular absorbent core, it achieves instant absorption, locking moisture without reverse seepage. Centered around the concept of "invisible protection + effortless wear/removal", Noda empowers users to regain freedom and live with ease.

PRODUCT RECOMMENDATION

| Size Category | Absorbency(ml) | Package |
|---------------|----------------|-------------------------------------|
| S | 800-1200 | ·Inner Package:10-20 pieces per bag |
| M | 1000-1400 | |
| L | 1200-1600 | ·Outer Package: Carton/Polybag |
| XL | 1400-1800 | |
| XXL | 1400-2000 | |

CUSTOMIZE YOUR PRODUCT

SAP

Ensures rapid absorption and dryness.

Dual Core

Provides enhanced protection for day and night use.

Leak Guard

Double barriers to prevent side leakage.

Tear-away Side

Easy removal for convenient disposal.



Wetness Indicator

Fades or changes color to signal changing time.

Breathable & Cloth-like Material

Soft and skin-friendly for maximum comfort.

Colored Stitching

Soft and skin-friendly for maximum comfort.

Stretch Panels

Flexible waistband for better fit and comfort.